

Induction Motor Speed Control Using PLC AND SCADA

Baidyanath Mohanty¹, Mahendra Kumar Sahoo² and Sunita Baral³

¹Assistant Professor, Department of Electrical Engineering, Aryan Institute of Engineering and Technology Bhubaneswar

²Assistant Professor, Department of Electrical, Raajdhani Engineering College, Bhubaneswar

³Assistant Professor, Department of Electrical Engineering, Capital Engineering College (CEC), Bhubaneswar

Abstract - Automation can be defined as the technology by which a process or way is performed without human succor. automatic control, is the use of various control system for operating equipment such as machinery, processes in industries, boilers and electrostatic precipitator, switching on communication networks, navigation and stabilization of ships, aircraft and other applications and vehicles with trifling human intervention. Some processes have been completely automated. The motor speed is controlled via the driver as an open loop control system. To make a more accurate closed loop control of motor speed we will use a tachometer (revolution-counter, tach, rev-counter, RPM gauge) to measure the speed and feed it back to the PLC, which compares to the desired value and take a control action, then the signal is transferred to the motor – via driver – to increase / decrease the speed. We will measure the speed of the motor using an incremental rotary encoder by adjusting parameters (PLC, driver) and also, we need to reduce the overall cost of the system. Our control system will be held using the available Siemens PLC. In addition, we will monitor motor parameters via SCADA system. Keywords- Variable Frequency Drive, Programmable Logic Controller, Supervisory Control and Data Acquisition.

1. INTRODUCTION

In any industry the induction motor plays an important role due to its are simple and rugged in construction. Advantage of induction motors are that they are robust and can operate in any environmental condition. Induction motors are cheaper in cost due to the absence of brushes, commutators, and slip rings. They are maintenance free motors unlike dc motors and synchronous motors due to the absence of brushes, commutators and slip rings. Induction motors can be operated in polluted and explosive environments as they do not have brushes which can cause sparks.³ phase induction motors will have self-starting torque unlike synchronous motors, hence no starting methods are employed unlike synchronous motor. By implementing a monitoring and control system for the speed of motor, the induction motor can be used in high performance variable-speed applications. To control the speed of these motor, a motor drive and control system with different methods can be used. An induction motor's speed enables affected by the supply frequency, change the number of motor stators, adjust the power input. In an induction motor, there is no electrical connection to the rotor, but currents are induced in the rotor circuit. The rotor conductors carry current in the stator magnetic field and thereby have a force exerted upon them tending to move them at right angles to the field. When

the stator winding of a three phase AC supply, a rotating magnetic field is established and rotates at synchronous speed. The direction of rotation of the field can be reversed by interchanging the connection to the supply of any two leads of a 3- phase induction motor. The control of equipment has been performed through the use of computers. Most equipment's use programmable logic controllers (PLC) to connect with computers to monitor each load and electricity consuming devices. A PLC interacts with the external world through its inputs and outputs. Especially in manufacturing companies, an automaton network concept developed under the name of Totally Integrated Automation (TIA). TIA includes actuator sensor level, field level, cellular level and process level control, which makes use of actuator-sensor interface, PROFIBUS and industrial Ethernet respectively. Through TIA, it is possible to view or control all the levels all the way to the actuators from process control level. In recent years, many companies started opening divisions in many countries around the world and wanted to connect and control any device from another or any place around the world (Distributed Management). Distributed management can be realized through Supervisory Control and Data Acquisition (SCADA) system. It is a common process control application that collects data from sensors on the shop floor or in remote locations and sends them to a central computer for management and control. A SCADA system includes input/output signal hardware, controllers, Human Machine Interface (HMI), networks, communication, database and software. The term SCADA usually refers to a system with a central unit that monitors and controls a complete site or a system spread out over a long distance. The bulk of the site control is actually performed automatically by a Remote Terminal Unit (RTU) or by a Programmable Logic Controller (PLC). [1, 2] A PLC-SCADA based monitoring and control system for a Variable Frequency Drive system was developed which controls a three-phase induction motor. The integration of PLC and SCADA for industrial automation comprises of: a human-machine interface which is the device presenting processed data to a human operator, who monitors and controls the process; a Remote Terminal Unit collects the information by connecting to sensors in the process, converting sensor signals to digital data and sending digital data to the supervisory system after which that information is displayed on a number of operator screens; PLC used as field devices for their economical, versatile, flexible and configurable attributes.

2. PROGRAMMABLE LOGIC CONTROLLER (PLC)

Richard E. Morley, who was the founder of the Modicum Corporation, invented the first PLC in 1969. A PLC is a solid-state device designed to perform the logic functions previously accomplished by components such as electromechanical relays, drum switches, mechanical timers/counters etc. for the control and operation of manufacturing process equipment and machinery. Even though the electromechanical relay (control relays, pneumatic timer relays, etc.) have served well for many generations often under adverse conditions, the ever-increasing sophistication and complexity of modern processing equipment requires faster acting, more reliable control functions that electromechanical relays or timing devices cannot offer. Relays have to be hardwired to perform a specific function, and when the system requirements change, the relay wiring has to be changed or modified.

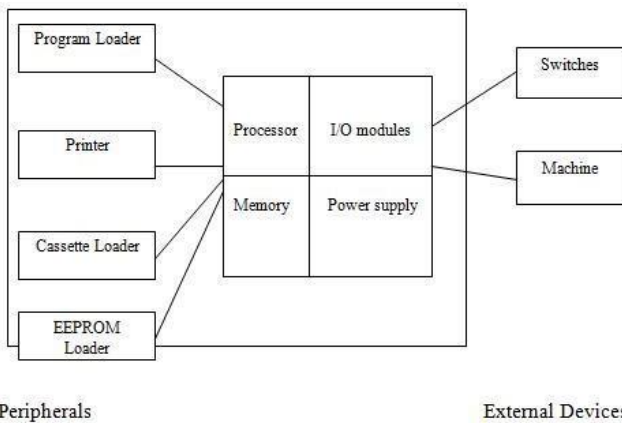

2. SUPERVISORY CONTROL AND DATA ACQUISITION

SCADA stands for Supervisory Control and Data Acquisition. SCADA refers to a system that collects data from various sensors at a factory, plant or in other remote locations and then sends this data to a central computer which then manages and controls the data. SCADA is a term that is used broadly to portray control and management solutions in a wide range of industries. One of key processes of SCADA is the ability to monitor an entire system in real time.

The main purposes for the use of a SCADA system would be to collect the needed data from remote sites and even the local site, displaying them on the monitor of the master computer in the control room, storing the appropriate data to the hard drive of the master computer and allowing the control of field devices (remote or local) from the control room. SCADA systems are equipped to make immediate corrections in the operational system, so they can increase the life-period of your equipment and save on the need for costly repairs. It also translates into man-hours saved and personnel enabled to focus on tasks that require human involvement.

BLOCK DIAGRAM

Proposed system block diagram shown in Fig.3 and it consists of two power supplies, one is 230V and other is 440V. The 230V supply from main is converted into 24V DC and it is given to the PLC unit. The second supply from main 440V is directly given to the VFD. The PLC (Programmable Logic Controller) unit in the block diagram is used to control the VFD and through the VFD the motor is controlled.

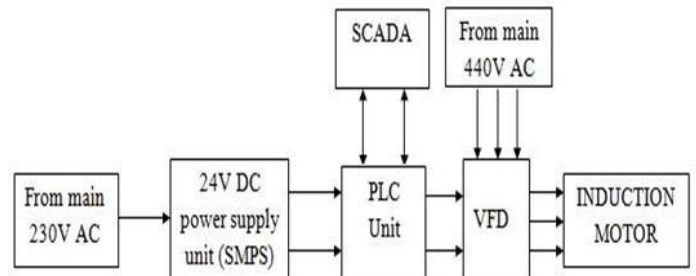

Fig.3 Block Diagram

PLC has memory for storing the user program or logic as well as a memory for controlling the operation of a process machine or driven equipment. The PLC is programmed in LADDER LOGIC (A high level, real world, graphic language that is easily understood by engineers). The speed of the motor is controlled by varying the frequency through Pulse width modulation controller. The variable frequency is set by using VFD. The VFD is connected with motor. By changing the output frequency, the motor speed can be varied.

3. VARIABLE FREQUENCY DRIVE (VFD)

A Variable Frequency Drive is used for applications wherein speed control is of an essential importance due to load changes wherein the speed needs to be increased or decreased accordingly. operating variable-speed drives with inverters offers a range of advantages compared to operation directly on the mains circuit: Prevents inrush current from occurring, as the inverter increases the frequency from 0 Hz instead of delivering a surge current of 50 Hz at motor start up; Any required degree of soft start and braking can be obtained by specifying the acceleration and deceleration time; If a different delivery rate is required for conveying liquid or gases, there is no need for the motor to work in its full capacity, thus leading to energy savings. V/f method of speed control The motor speed can be controlled by varying the supply frequency. The voltage induced in the stator is directly proportional to product of supply frequency and air-gap flux. If stator drop is neglected, terminal voltage can be considered proportional to product of frequency and flux. $V_1 \propto f \cdot \Phi$ Effect of supply frequency change without terminal voltage change: 1. Reduction of supply frequency without change in terminal voltage will cause an increase in the air gap flux thereby saturating the motor. This will cause the increase in magnetizing current, core loss and stator copper

loss and cause distortion in line current and voltage and produce high-pitch noise. 2. An increase of supply frequency without change in terminal voltage will cause decrease in flux, therefore leading to reduction of torque capability of the motor. A driver used in control system is Siemens (micro master 440). [3]

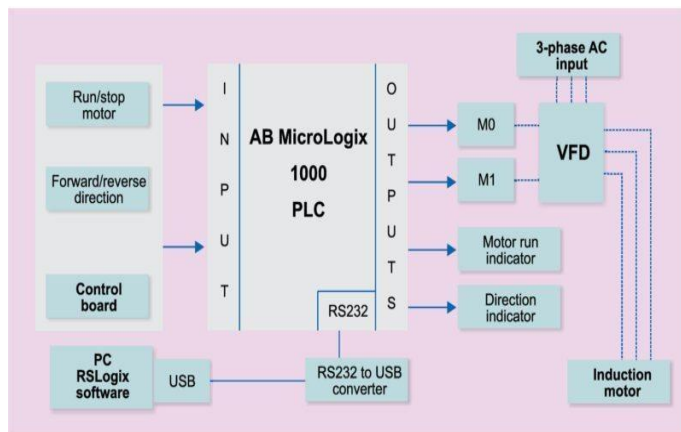

4. THREE PHASE INDUCTION MOTOR

An electrical motor is such an electromechanical device which converts electrical energy into a mechanical energy. In case of three phase AC operation, most widely used motor is Three phase induction motor as this type of motor does not require any starting device or we can say they are self-starting induction motors. For better understanding, the principle of three phase induction motor, the essential constructional feature of this motor must be known to us. This Motor consists of two major parts:

Stator:

Stator of three phase induction motor is made up of numbers of slots to construct a 3-phase winding circuit which is connected to 3 phase AC source. The three-phase winding is arranged in such a manner in the slots that they produce a rotating magnetic field after 3Ph. AC supply is given to them.

Rotor:

Rotor of three phase induction motor consists of cylindrical laminated core with parallel slots that can carry conductors. Conductors are heavy copper or aluminum bars which fit in each slot & they are short-circuited by the end rings. The slots are not exactly made parallel to the axis of the shaft but are slotted a little skewed because this arrangement reduces magnetic humming noise & can avoid stalling of the motor.

Production of Rotating Magnetic Field:

The stator of the motor consists of overlapping winding offset by an electrical angle of 120°. When the primary winding or the stator is connected to a 3 phase AC source, it establishes a rotating magnetic field which rotates at the synchronous speed

SPEED OF AN INDUCTION MOTOR:

A three phase induction motor is basically a constant speed motor so it's somewhat difficult to control its speed. The speed control of induction motor is done at the cost of decrease in efficiency and low electrical power factor. Before discussing the methods to control the speed of three phase induction motor one should know the basic formulas of speed and torque of three phase induction motor as the methods of speed control depends upon these formulas. Synchronous Speed

$$N_s = \frac{120f}{P}$$

Where, f = frequency and P is the number of poles.

The speed of induction motor is given by,

$$N = N_s(1 - s)$$

Where, N is the speed of rotor of induction motor, N_s is the synchronous speed, S is the slip. There are two types of speed control method of three phase induction motor.

Speed Control from Stator Side

1. **V / f control or frequency control** - Whenever three phase supply is given to three phase induction motor rotating magnetic field is produced which rotates at synchronous speed given by

$$N_s = \frac{120f}{P}$$

2. In three phase induction motor EMF is induced by induction similar to that of transformer which is given by

$$E \text{ or } V = 4.44\phi K.T.f \text{ or } \phi = \frac{V}{4.44KTf}$$

3. Where, K is the winding constant, T is the number of turns per phase and f is frequency. Now if we change frequency synchronous speed changes but with decrease in frequency flux will increase and this change in value of flux causes saturation of rotor and stator cores which will further cause increase in no load current of the motor. So, its important to maintain flux, φ constant and it is only possible if we change voltage. i.e if we decrease frequency flux increases but at the same time if we decrease voltage flux will also decrease causing no change in flux and hence it remains constant. So, here we are keeping the ratio of V/f as constant. Hence its name is V/f method. For controlling the speed of three phase induction motor by V/f method we have to supply variable voltage and frequency which is easily obtained by using converter and inverter set.
4. Controlling supply voltage Changing the number of stator poles: The stator poles can be changed by two methods

5. Multiple stator winding method.
6. Pole amplitude modulation method (PAM)
7. Multiple stator winding method – In this method of speed control of three phase induction motor, the stator is provided by two separate winding. These two stator windings are electrically isolated from each other and are wound for two different pole numbers. Using switching arrangement, at a time, supply is given to one winding only and hence speed control is possible. Disadvantages of this method is that the smooth speed control is not possible. This method is costlier and less efficient as two different stator winding are required. This method of speed control can only be applied for squirrel cage motor.
8. Pole amplitude modulation method (PAM) – In this method of speed control of three phase induction motor the original sinusoidal MMF wave is modulated by another sinusoidal MMF wave having different number of poles.

Speed Control from Rotor Side

1. Adding external resistance on rotor side
2. Cascade control method

5. CONCLUSION

The goal of this project was motivated to control Speed of motor using PLC (Siemens) S7-300, converter micro master 440, incremental rotary encoder instead of the encoder (Siemens) because the incremental encoder is cheaper than encoder (Siemens) and performs the same action as encoder (Siemens) so that we adjust the parameters of count in hardware configuration for controlling the frequency measurement and adjust the parameters of PI control to obtain the determine the speed in PLC programming as shown in the results of the above figures. Also in this project we were motivated to monitor the speed of three phase induction motor using a SCADA system. The control system is designed based on the most advanced technology which gives a high amount of flexibility and efficiency. Monitoring system gives facility of analyzing the operation of induction motor in an online / offline mode, which makes the system to be safe from any fault/error conditions.

REFERENCES

- [1] Yasar Birbir, H.Selcuk Nogay, "Design and Implementation of PLC-Based Monitoring Control System for Three-Phase Induction Motors Fed by PWM Inverter", international journal of systems applications, engineering & development, 2(3), 2008
- [2] Ali Gulabi," Development of an Embedded SCADA System with PLC and Java Application for Synchronous Operation of Standard Servo Drives", Master thesis,

Faculty of Engineering and Computer Science of the University of Applied Sciences Hamburg, May 2007

- [3] Rinchen Geongmit Dorjee, "Monitoring and Control of a Variable Frequency Drive Using PLC and SCADA", International Journal on Recent and Innovation Trends in Computing and Communication, 2 (10), October 2014D